



Project:  
Item:  
Quantity:

VACUUM PACKING MACHINE JUMBO 35 - SPEC SHEET

**JUMBO 35**  
**VACUUM PACKAGING MACHINE**



**FEATURES**

- Seal bar length: 13.5"
- Seal bar with two wires, for double security
- Seal bar easily removable for cleaning and maintenance purposes
- Pump capacity: 678 cf/h (19 m<sup>3</sup>/h) Busch vacuum pump
- Pump maintenance and cleaning program
- Machine cycle: 15-30 sec
- Time control: 1-99 sec
- Transparent lid, which opens automatically after every cycle
- Deep drawn vacuum chamber
- Comes with insert plates for a faster cycle and product adjustment
- Stainless steel exterior
- 6ft cord with Nema 5-15P plug
- Standard with service kit

**DESCRIPTION**

The robust, stainless steel Jumbo 35 vacuum packer is standard equipped with a Busch vacuum pump, is ETL listed and complies with UL, CSA and CE standards.

**OPTIONS AND ACCESSORIES**

- Cut-off/Wide seal
- Inclined insert plate
- Food container adaptor
- Cart with castors and shelf



**WARRANTY**

Henkelman Inc offers a warranty of 1 year on labor and 3 years on parts. For full warranty details, please refer to [www.henkelman.com](http://www.henkelman.com).

DATE

APPROVAL



FIT FOR FOOD SERVICE  
[WWW.HENKELMAN.COM](http://WWW.HENKELMAN.COM)

HENKELMAN INC.  
493 W Fullerton Ave  
Elmhurst IL, 60126

**Sales and technical support**  
P +1 331 979 2013  
F +1 630 359 3875  
E [info@henkelmanusa.com](mailto:info@henkelmanusa.com)  
**Service and warranty**  
P +1 844 208 5685

# VACUUM PACKING MACHINE JUMBO 35 – SPECS

VACUUM PACKING MACHINE JUMBO 35 – SPEC SHEET

## DIMENSIONS

In inches

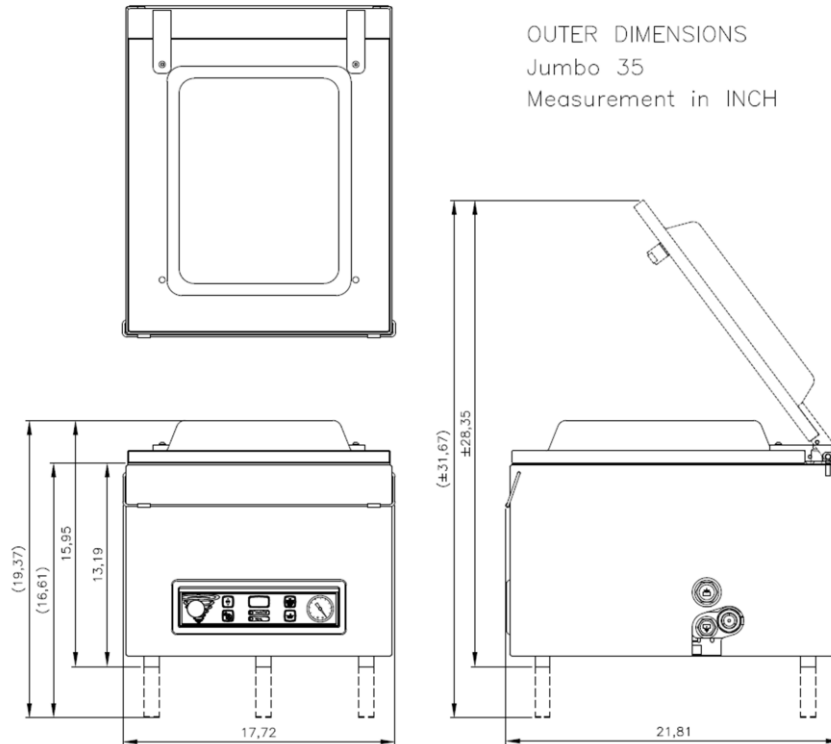

Model	Dimensions (inches)		Volts	Amps	Hz	Pump capacity	HP	Plug	Weight (lbs)
	Chamber (usable space) LxWxH	Machine LxWxH							
Jumbo 35	14.5"x13.5"x6"	21.8"x17.7"x15.9"	110-120V	9	60Hz	678 cf/h (19 m <sup>3</sup> /h)	0.74	NEMA 5-15P	112

NEMA 5-15P



15 A/125 V



FIT FOR FOOD SERVICE  
[WWW.HENKELMAN.COM](http://WWW.HENKELMAN.COM)

HENKELMAN INC.  
 493 W Fullerton Ave  
 Elmhurst IL, 60126

Sales and technical support  
 P +1 331 979 2013  
 F +1 630 359 3875  
 E [info@henkelmanusa.com](mailto:info@henkelmanusa.com)  
 Service and warranty  
 P +1 844 208 5685