



Project:

Item:

Quantity:

COMBIVAC BOXER 42XL
VACUUM PACKAGING MACHINE



FEATURES

- Seal bar length: 16.5"
- Seal bar with two wires, for double security
- Seal bar easily removable for cleaning and maintenance purposes
- Pump capacity: 889 cf/h (25 m³/h) Busch vacuum pump
- Pump maintenance and cleaning program
- Machine cycle: 20-40 sec
- **Standard Advanced Control System (ACS)** with Sensor control: max. 99.8%, for an optimum and consistent vacuum and cycle time
- Soft Air to protect the product and vacuum pouch
- 20 program memory (ACS)
- Transparent lid, opens automatically after every cycle
- Deep drawn vacuum chamber
- Comes with insert plates for a faster cycle and product adjustment
- Stainless steel exterior
- 6ft cord with Nema 5-15P plug

DESCRIPTION

The robust, stainless steel Boxer 42XL vacuum packer is standard equipped with a Busch vacuum pump. This Combivac machine is ETL listed and complies with UL, CSA and CE standards.

OPTIONS AND ACCESSORIES

- Cut-off seal (\$0)
- Wide seal (\$0)
- Inclined insert plate
- Food container adaptor
- Cart with castors and shelves
- Liquid Control



WARRANTY

Henkelman Inc offers a warranty of 1 year on labor and 3 years on parts. For full warranty details, please refer to www.henkelman.com.

DATE

APPROVAL



FIT FOR FOOD SERVICE
WWW.HENKELMAN.COM

HENKELMAN INC.
 493 W Fullerton Ave
 Elmhurst IL, 60126

Sales and technical support
 P +1 331 979 2013
 F +1 630 359 3875
 E info@henkelmanusa.com
Service and warranty
 P +1 844 208 5685

VACUUM PACKAGING MACHINE BOXER 42 XL - SPEC SHEET

VACUUM PACKING MACHINE BOXER 42XL – SPECS

VACUUM PACKING MACHINE BOXER 42XL – SPEC SHEET

DIMENSIONS

In inches

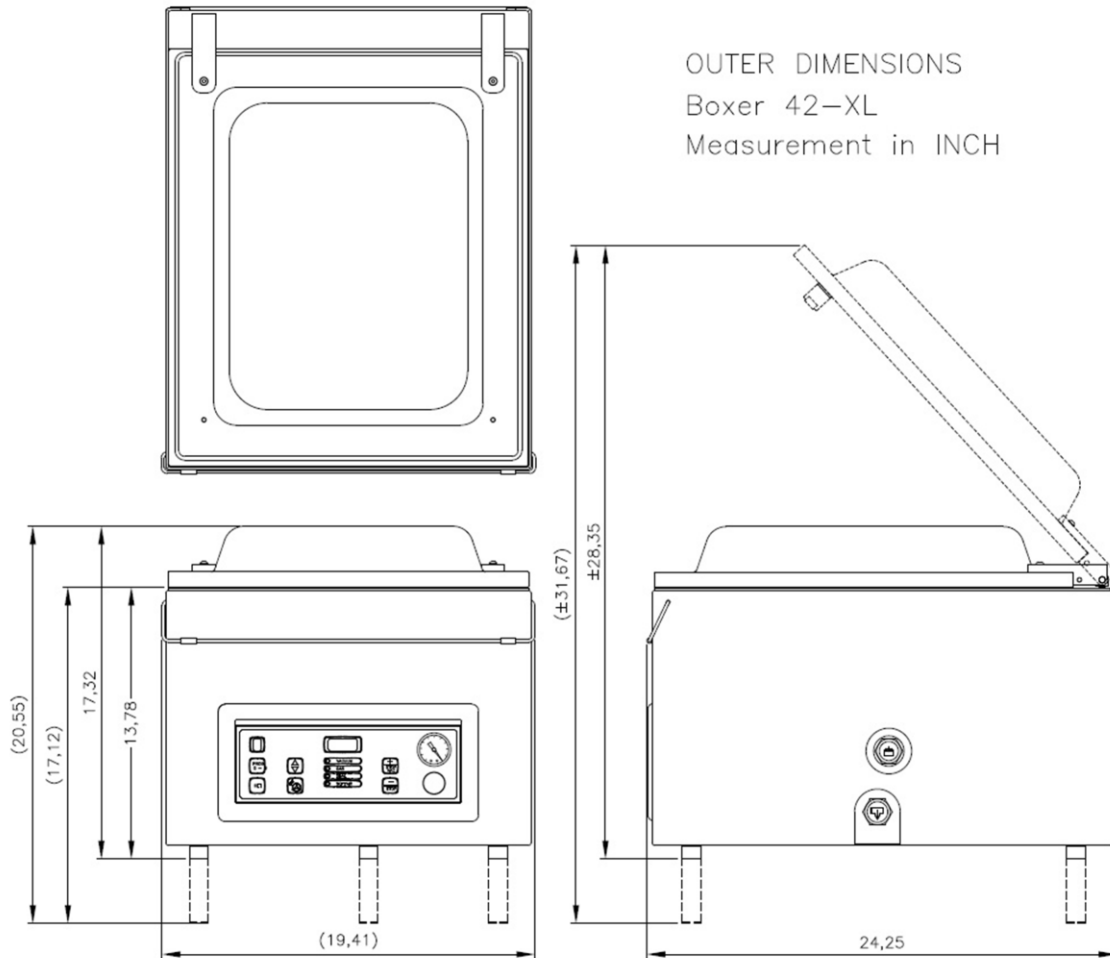

Model	Dimensions (inches)		Volts	Amps	Hz	Pump capacity	HP	Plug	Weight (lbs)
	Chamber (usable space) LxWxH	Machine LxWxH							
Boxer 42XL Combivac	18"x16.5"x7"	24.2"x19.4"x17.3"	110-120V	13	60Hz	889 cf/h (25 m ³ /h)	1.34	NEMA 5-15P	159



ORIGINAL HENKELMAN
VACUUM SYSTEMS

FIT FOR FOOD SERVICE
WWW.HENKELMAN.COM

HENKELMAN INC.
493 W Fullerton Ave
Elmhurst IL, 60126

Sales and technical support
P +1 331 979 2013
F +1 630 359 3875
E info@henkelmanusa.com
Service and warranty
P +1 844 208 5685